



# Rugged, Multi-Application Sensing, Datalogging and Analytic System

## FA1050X

### FEATURES

- CO2 sensing and capture**
- Suitable for any gas capture and datalogging**
- Temperature and wind measurements**
- Humidity measurement**
- Pollution estimation from gas, like CO2**
- Measurement of soil characteristics**
  - Temperature, nutrients, gas, humidity**
- Rugged and stable over extreme temperature**
- Cellphone interface**
- Remote sensing capability**
- Multi-year datalogging capability**
- Grid and battery powered**

### GENERAL DESCRIPTION

The FA1050X is a rugged, high-performance embedded microelectronics system with broad range of applications. It is engineered for complex measurements and control functions. It incorporates intelligent control engines that guarantee reliability under extreme conditions, and remote sensing.

Light weight, GSM interface, and easy operation make FA1050X your ideal data-acquisition system, for gas, temperature, humidity, light, and wind. The core is a proprietary Flexible Arithmetic Engine implemented as an embedded microelectronics system. It is reconfigurable and adaptive, with interface to computers and cellphones. It is protected, partly, by US Patent No. 60/922,260.

### APPLICATIONS

- Industrial gas sensing and capturing
- City CO2 pollution measurement
- Agriculture
  - Soil humidity, temperature, wind
  - Nutrients, remote farm monitoring, etc
- Capture of any gas (with appropriate sensor)

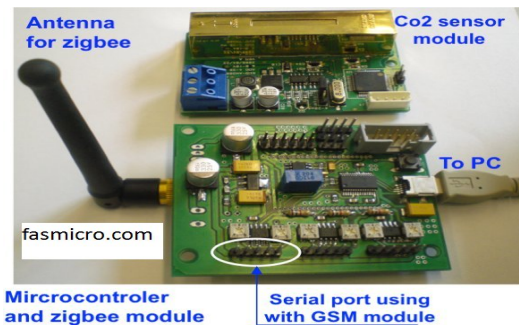

FA1050X System

We are looking for governments, government agencies, universities, federal ministries, and commissions to partner with us to implement robust systems based on FA1050X. We provide CO2 pollution management, farm monitoring, industrial gas sensing, etc.

**Introduction:** FA1050X detects and captures any type of gas. For example, it has the capacity to capture and provide real time amount of carbon dioxide (CO2) in a city. For energy companies or city governments interested in estimating the amount of CO2 in the air, our technology is developed for such a need. We help you collect CO2 over a period of time, using our distributed CO2-sensors, across your villages or cities. We will help you analyze the data and quantify impacts on human health. With these results, policymakers can make decisions and appropriate steps taken. Our technology is very robust to cover the whole of Lagos, for instance.

For farmers, FA1050X will remove the guess work out of farming. Our technology will help you estimate the necessary nutrients in the soil and in the farm environment. By incorporating wind vanes and anemometers, we gather data over a long period of time on wind direction and speed. This could be useful for university researchers. When we incorporate the right sensors in the soil, we can provide up to minute data on the nutrient contents of soil. With cellphone interface, you do not have to leave your house to know if it rained in the farm, separated by 100 miles, from your home.

For home and industrial uses, our technology will help you monitor gases of any type with appropriate sensor.

**Design:** The general architecture of the system is shown below.

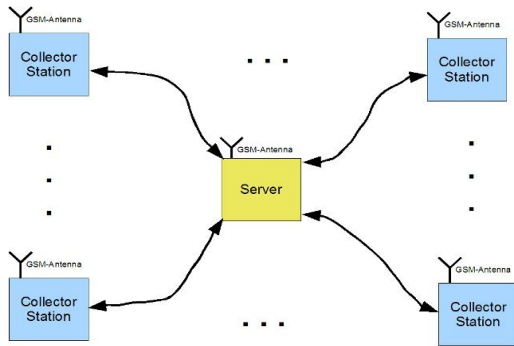

Overall System Architecture

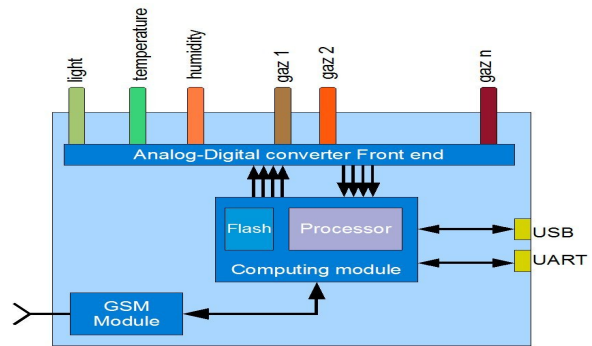

Internal architecture of a collector station

A set of collector stations installed in a town will be used to capture the data, which will periodically be sent to a central server for inclusion in the database. The collected data are locally saved for fault tolerance purposes. If the network connection is not available, then saved data can be read from the collector stations by an operator. In case of a network failure, the collector stations will be read once a day, which means that they should be able to store the data locally at least for 24H. Also for sake of fault tolerance, data will be read once a day to provide comparison between transmitted data and lift possible transmission errors.

As shown on figure a collector station consists of:

- a set of sensors, each of which is used to detect the presence of a given gas as well as its density.
- a central computing module in charge of the management of the collector station. Data collected from the sensor are first processed in the computing module and packetized for transmission via the GSM-module. Also the same data are copied to the non volatile memory on the collector.
- a non volatile flash memory for temporarily storing the data. This can store data for years.
- a communication module, GSM Module, directly connected to the computing module.
- a USB interface is provided for communication with the external world. In case of network failure, an operator should be able to collect the data from the platform. A hermetic plastic box will be used to protect the components from water and dust.
- a battery for non interruption of operation upon power failure.

FA1050X consists of three main modules.

- **The GAS sensor** module produces an analog output signal, whose strength is related to the amount of gas in the air, for example, CO<sub>2</sub>. This signal is digitized and computed by the **computing module**.
- Thereafter, the computing module sends the digitized data in three different ways to the main station.
  - **GSM modem:** Data are packed in small messages and sent over the GSM network using the GSM-Modem. Figure below shows an example of message received on a mobile phone from our CO<sub>2</sub> module.
  - **Zigbee Network:** The Zigbee network provides the possibility to build mesh networks in a given area. The messages are then sent from system to system to a central system featuring a GSM modem. From this central system, data will be packed and send over the GSM network.
  - **USART to USB communication** to send data by using a USB cable between computing module and the main station. This is only used for maintenance, or in regions where no GSM network is available, as in faraway farms.



CO2 data, received on Cellphone

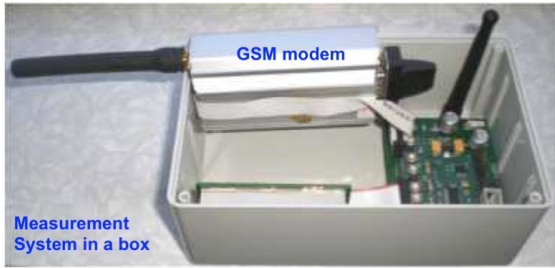

FA1050X in Hermetic Chassis



## First Atlantic Semiconductors & Microelectronics Ltd

(RC908703)

Advisory, Research, Training, Contracting

P.O.Box 5385 Aba, Abia State, Nigeria

Phone: 0803 425 1210

Email: [info@fasmicro.com](mailto:info@fasmicro.com) Web: <http://fasmicro.com>

---